



METAL CEILING & WALL CLADDING

INDEX

Our Products Range

1. Why use Metafino metal False Ceiling system 04
2. Metfino Suspended Grid System 05
3. 24mm / 15mm Tee Grid System 06
4. Lay-in System 07
5. Clip-in-System 08
6. Clip-in Swing down System 09
7. Open Cell Ceiling System 10
8. 84R Linear Ceiling System 11
9. 84 C / 184 C Linear Ceiling System 12
10. 150 F Linear Ceiling System 13
11. 150 C Linear Ceiling System 13
12. 300 C Linear Ceiling System 14
13. Sun Louver System 14
14. Baffle Ceiling Systems 15
15. Fixing Accessories 16
16. Gypsum Ceiling Section 17-18
17. Chemical Composition for Aluminium Alloy 19

WHY USE FALSE CEILINGS?

In every modern building, the ceiling is an important part of the interiors. There are many reasons why suspended ceilings are gaining wide acceptance in modern buildings. Some of them are:

Access to the plenum

The creation of a plenum allows the installation of air conditioning while a suspended ceiling facilitates access to this plenum. Accessibility to services such as electric, heating, ventilation, smokes detection. A telephone, air and sprinkler system is one of the important functions of suspended ceilings. **Metafino** All ceilings are designed to allow easy access. Tiles or panel may be lifted out to allow inspection, maintenance, installation or removal of concealed services.

Acoustics

Noise is major concern when designing indoor spaces. Room sound absorption is one of the most important factors in controlling built-up reverberant noise and in reducing sound transmission between rooms. Perforated Suspended ceilings provide good acoustics control both by helping to reduce sound within a room and by reducing sound transmission from room to room. Modern buildings are increasingly becoming noisy places with high people density and instrument and appliance noise. This reduces work efficiency and comfort by increasing tension, stress and irritation. Suspended acoustical ceilings serve to provide sound absorption on the most useful surface in a room. They help in reducing reverberant sound intensity within a room.

Metafino ceiling range comprises perforated panels with an acoustic non-woven material factory applied to the rear of the panels. Due to the controlled sound impedance of this perforated panel, and with a backing air space (ceiling plenum), the **Metafino** ceiling provides excellent sound absorption properties without the use of any fibrous material behind the perforated panel.

Fire Protection

Suspended ceilings should be carefully evaluated for their fire resistance and fire reaction. Ceilings should not aid fire by being combustible or letting off harmful gases or smoke, while under fire. Ceiling should not melt, break or deformed under normal fire conditions.

Thermal Insulation

Suspended False Ceilings help in Thermal Insulation of buildings. Due to superior Thermal Insulation property of the ceiling material external heat is kept outside while air-conditioned cooling is preserved inside.

Why use Metafino False Ceilings? When selecting False Ceiling Systems, the following considerations should be taken into account:

- ⇒ Affordability, including installation cost and life-cycle costs.
- ⇒ Appearance.
- ⇒ Availability.
- ⇒ Color and light reflectance values.
- ⇒ Flame spread and fire resistance.
- ⇒ Maintainability and refinish ability of materials.
- ⇒ Panel size and shape preferences.
- ⇒ Recycle ability.
- ⇒ Resistance to environmental conditions such as high humidity or wind loads.
- ⇒ Strength and durability.
- ⇒ Technical support from manufacturer.
- ⇒ Thermal insulation (if an insulated ceiling is required).
- ⇒ Weight (an especially important consideration in building renovation projects).

The combination of all these features makes **Metafino** Ceilings the ideal choice form high quality ceilings in Office Buildings, Hotels, Hospitals, Education Facilities, Airport Buildings, Shopping Centers, Residences and virtually any other conceivable building.

METAFINO SUSPENDED GRID SYSTEM

Metafino The Ceiling suspension system shall be exposed lay in system to fit 600mm x 600 mm or 600 mm x 1200 mm ceiling module. It shall be suspended to the soffit by a 4mm diameter adjustable quick fit hanger rod system. Main Tee shall be in 38mm/32mm height exposed portion (polyester coated) shall be 24mm. Cross tee shall be 26mm height and expose portion is 24mm. All systems components are made of roll formed hot dipped galvanized steel of 0.30mm thickness with zinc coating of not less than 100/120gsm/m² and a minimum tensile strength of 240 mpa. wall angle are 24mm height x 24mm expose portion made of 0.35mm thick pre coated coil. Both ends of the Main Tee have integral splices which can be enjoyed firmly by inserting a tab on the one end of one section into slot in the adjoining section. The exposed flange finish shall be pre painted polyester coated galvanized steel not less than 0.30 in white colour with coating thickness of 20 microns top coat and 8 microns primer alkyd backer on backside.



ADVANTAGES

It is economical, easy to install, using less labour to complete the installation at minimum time as compared with conventional extruded aluminium tee system. Interchangeability of main and cross tees between systems, promotes lower inventory requirements and greater field flexibility. The straight entry locking features of the section allows the system to be installed easily within close proximity of the overheads. The system promotes complete designs flexibility and it is capable of 'sustaining loads normally designed into suspended tee system refer to load table) overlap type of cross tee provide complete flush joint, eliminating gaps between main runner and cross tees and ensure rigidity at fixtures. In line cross tees provide true double-lock action.



SPECIALITIES FOR T GRID SYSTEM

- » Steel material is processed by pre painted ho-dip galvanized steel.
- » Our Zinc Mass Coating is 120gm/m² Salt spray test for the white pre-painted cap is for 1000-Hours. The Material is processed with 20 micron polyester pre-painted.
- » The anti-rusty process has been incorporated into the galvanized steel.
- » T-bars are produced by fully automatic machine controlling the production of straight material to maximum 0.1 mm tolerance ensuring consistent dimensioning of the grid module after installation.
- » Load bearing capacity when the span is 1.2 meter, supported with hanger wire from roof for type 1 is 8.45 kg/m² and type II is 12.05 kg/m²



TEE GRID SYSTEM

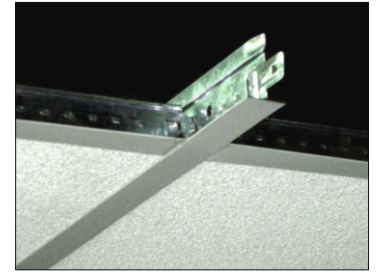
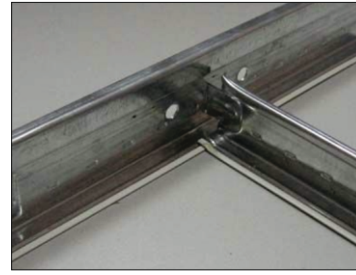
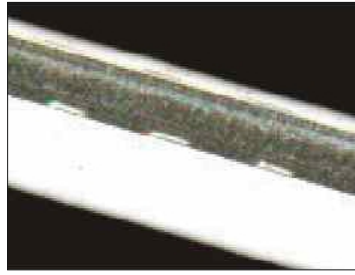
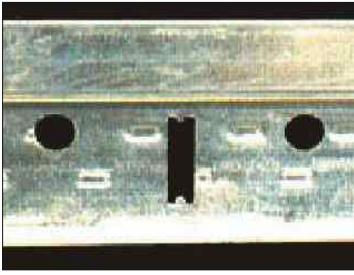

| Part Name | Main Tee | Cross Tee |
|-------------------|--|---|
| Heavy Duty | <p>38x24x3600x0.30mm Qty/Box-25 Nos.</p> | <p>38x24x1200x0.30mm 38x24x600x0.30mm Qty/Box-40 Nos.</p> |
| Standard | <p>38x24x3600x0.30mm Qty/Box-25 Nos.</p> | <p>26x24x1200x0.30mm Qty/Box-50 Nos. 26x24x600x0.30mm Qty/Box-75 Nos.</p> |
| Regular | <p>32x24x3600x0.30mm Qty/Box-25 Nos.</p> | <p>26x24x1200x0.30mm Qty/Box-50 Nos. 26x24x600x0.30mm Qty/Box-75 Nos.</p> |
| Regular | <p>32x15x3600x0.30mm Qty/Box-25 Nos.</p> | <p>26x15x1200x0.30mm Qty/Box-50 Nos. 26x15x600x0.30mm Qty/Box-75 Nos.</p> |
| Wall Angle | <p>24x24x3000x0.40mm Qty/Box-50 Nos.</p> | <p>15x15x3000x0.40mm Qty/Box-50 Nos.</p> |



Metafino Lay-in false Ceiling System with steel/aluminium tile 595 mm X 595 mm is manufactured out of 0.50 mm thick polyester coil coated galvanized steel 120 gsm zinc coating or 0.7mm aluminium powder coated with 60 microns polyester paint in AA5050, AA3105 or AA1050 alum. alloy these tiles can have square or beveled edges . Coil coated steel tile has 20-micron polyester coated finish and back coat of 8-micron alkyd primer. The exposed metal grid comprises of Main Runners and Cross Tees, roll formed from galvanized steel of 120gsm zinc coating. The main and cross tees are provided with bayonet coupling for quick installation and have a height of 32/38 mm and 26 mm. The grid is suspended from the roof with G.I. wire rods for quick adjustment by suspension hangers at max. 1200 mm and is filled with 1200 mm / 600 mm cross tees. Hangers are fixed to roof by expansion fasteners. Wall angle are 24 mm X 24 mm X 0.4 mm thick coil coated steel matching the colour of the tile.



Finish of the tiles: Tiles are available in plain and perforation of 2.2, 2.5mm and 1.8mm

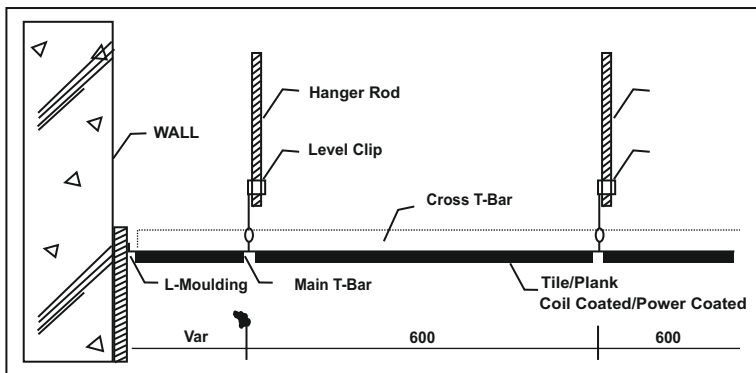



Metafino Clip-in False Ceiling System with steel/aluminium tile (600 mm x 600 mm) is manufactured out of 0.50 mm thick polyester coil coated galvanized steel 120 gsm zinc coating or 0.7mm aluminium powder coated with 60 microns polyester paint in AA5050, AA3105 or AA1050 alum. alloy. These tiles can have square or beveled edges. Coil coated steel tile has 20-micron polyester coated finish and back coat of 8-micron alkyd primer. Two sides of each tile are raised and piped and stopped to ensure positive engagement into the spring Clip-in profile, yet allow for demounting of individual tiles. The rigid suspension system

consists of rows of 0.5 mm galvanized steel Clip-in profiles of size 40 mm X 17 mm or 34 mm X 24 mm, installed at 600 mm c/c spacing to support the tiles. Suspension Angles are suspended from the roof structure by GI Ceiling Brackets. They are joined to the Clip-in Profiles by Hold-on Clamps. The tiles / planks are held in place by pressure clips. In the flexible system the Hanger and Butterfly Clip replace the suspension angle. Wall angle or Edge Profile are of size 24 mm X 24 mm and 0.4 mm thick. They are made of coil coated steel or aluminium matching the colour of tiles.

Finish of the tiles: Tiles are available in plain and perforation of 2.2mm, 2.5mm and 1.8mm

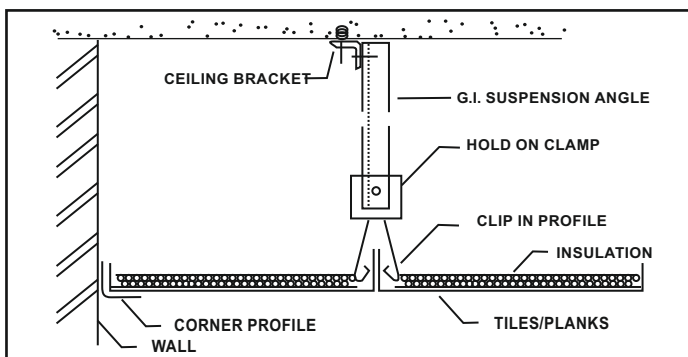

CLIP-IN SYSTEM

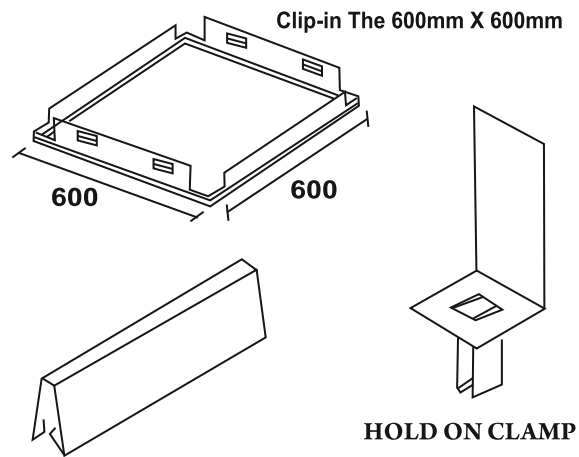

CLIP IN PROFILE

CLIP-IN SWING DOWN SYSTEM

Metafino Clip-in false Ceiling System made of Galvanized steel /Aluminium swing down tiles (600 mm x 600 mm) are manufactured out of 0.50 mm thick polyester coil coated steel 100/120 gsm zinc coating or powder coated with 60 microns polyester paint. Aluminium tiles are manufactured out of 0.70mm thick aluminium sheets with powder coated



60 microns polyester paint. These tiles can have beveled or straight edges. Coil coated galvanized steel tiles have 20 microns polyester coated finish on front side and 8 microns alkyd primer coating on backside. These swing down tiles are available in plain and perforation of 2.2 mm, 2.5 mm and 1.8 mm.

Two side of each tile are raised and piped stopped to ensure positive engagement into the spring clip-in profile, yet allow for swing down of individual tile. The rigid suspension system consists of rows of 0.50 mm galvanized steel clip-in profiles of size 40 mm x 70 mm or 34 mm x 24 mm which are suspended and jointed from galvanized steel C Channels of size 10 mm x 38 mm x 10 mm with hold on clamps. Clip-in profiles are installed at 600 mm c/c spacing to support the swing down tiles. C Channels are 3600 mm long



and spaced at 1200 mm centers and securely fixed with suspension angles. Suspension angles are suspended from the roof structure by G.I Ceiling brackets. In the flexible system the rod hanger and butterfly clip replace the suspension angle. Wall angle or Edge profile are of size 24 mm x 24 mm and made of 0.4 mm thick coil coated white colour sheet matching the colour of tiles.

OPEN CELL CEILING SYSTEM

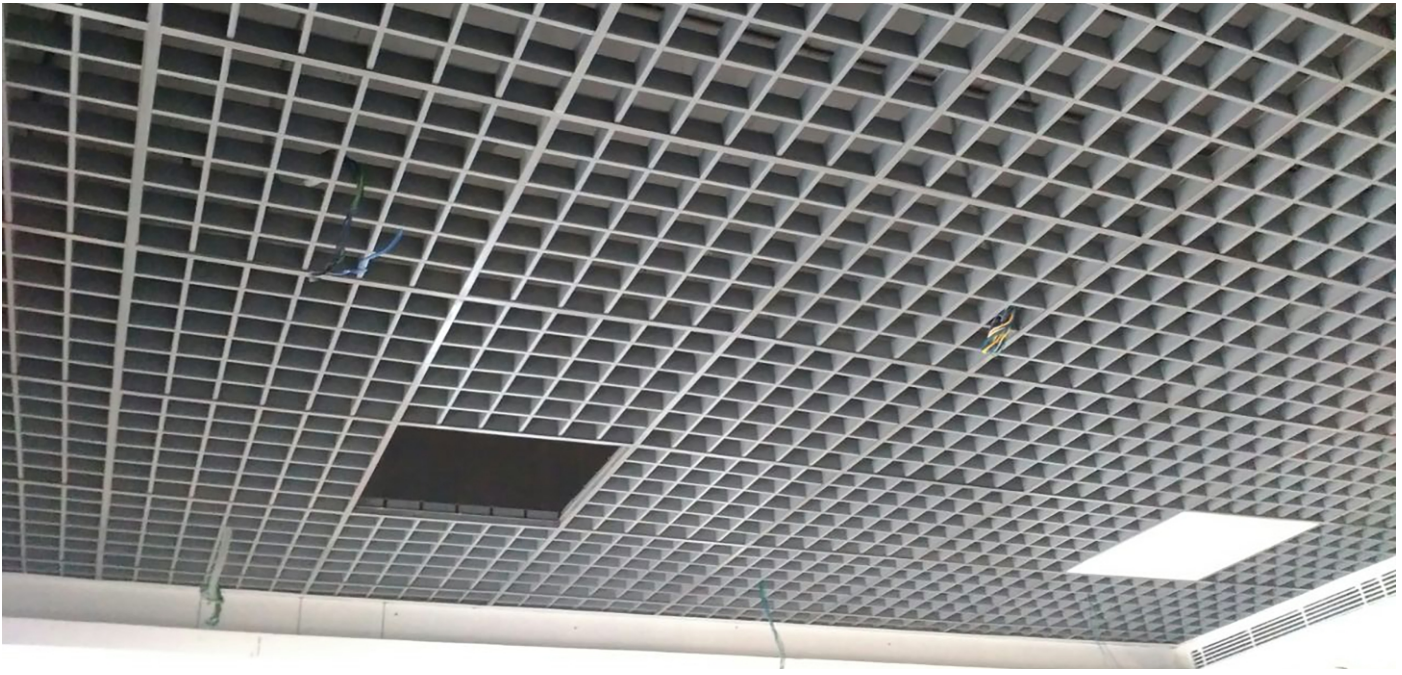

Metafino aluminum open cell ceiling tiles are designed Advantages

to lay onto 15mm Tee Grid. These tiles can be used without any tee grid system also. Access is gained by simply lifting the tiles out of the grid. The new Lock-In system features open cell ceiling panels with no frame or border around them. The panels simply connect to each other with easy lock in system of main and cross.

When grid system is not required, the Lock-In system of Main and Cross provides architects and designers with additional flexibility, especially in customized sizes and different colors.

- Easy access to lighting, ventilation systems, and sprinklers
- Strong sense of three-dimension
- The product can be match will all type of light fixtures
- The product plays a prominent role in exhaust ventilation
- Versatile range of patterns, configurations, and colors
- Available in various interior cell sizes
- Eco-friendly

Uses

- Airports
- Reception Areas
- Bus Stations
- Lobbies
- Railway Stations
- Banquette Halls
- Corridors
- Showrooms
- Department Stores

Technical Details

- **Standard Module Cell Size**
- 75mm x 75mm, 100mm x 100mm, 150mm x 150mm, 200mm x 200mm, 300 mm x 300 mm
- **Web Height: 50 mm**
- **Width : 15 mm**
- **Thickness: 0.35 mm G.I.**
0.45 mm Aluminium
- **Finish:** powder-coated(epoxy polyester paint) and limitless colors
- **Dimensions:** other customized dimensions also available as per factory confirmation.
- **Substrate:** Aluminum alloy / Galvanised Steel
- **Tee Grid:** Main runner-3600 mm x 15 mm x 32 mm x 0.30 mm
Cross tee- 1200 mm x 15 mm x 26 mm x 0.30 mm
Cross tee- 600 mm x 15 mm x 26 mm x 0.30 mm
Wall Angle- 3000 mm x 15 mm x 15 mm x 0.40 mm

Tile size - 595 mm x 595 mm

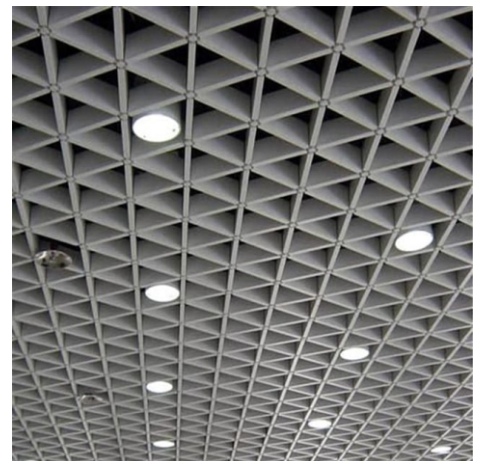

LINEAR CEILING SYTEM

Metafino Linear or strip ceilings provide an aesthetic linear finish to any interior.

Available in a variety of profiles and modules, including 84R, 84C, 184C 150F, 150C and 300C

The panels are available in coil coated steel and aluminium substrates. Perforated profiles are available 2.2, 2.5mm and 1.8mm perforation for acoustic applications.

Panels are available in lengths up-to 5-6 meters, to suit your design requirements

84R LINEAR CEILING SYSTEM

84 R ceiling system comprises of 84 mm x 16 mm panels without flush profile (for 100 mm module only) roll formed out of metal coils. Panels are fixed on to roll formed carriers 32 mm wide x 39 mm deep made out of 0.9 mm Aluminium or 0.5 mm galvanised steel sheet with cutouts to hold the panels in module of 100 mm at maximum 1.5 mm without insulation and at maximum 1.2 m c/c with insulation. Carriers are suspended from the roof or truss by 4 mm dia. galvanized steel wire rod hanger with special height adjustment suspension clip at max. 1.2 m c/c. Hangers are fixed to the roof by ceiling bracket. Panels are available in max. Lengths up to maximum 5 m to suit site dimensions.. Edge profiles or wall angles are 24 mm X 24 mm X 0.4 mm thick and match the colour of the panel. Flush profile can be use in between 2 panels to fill gap of 16mm.

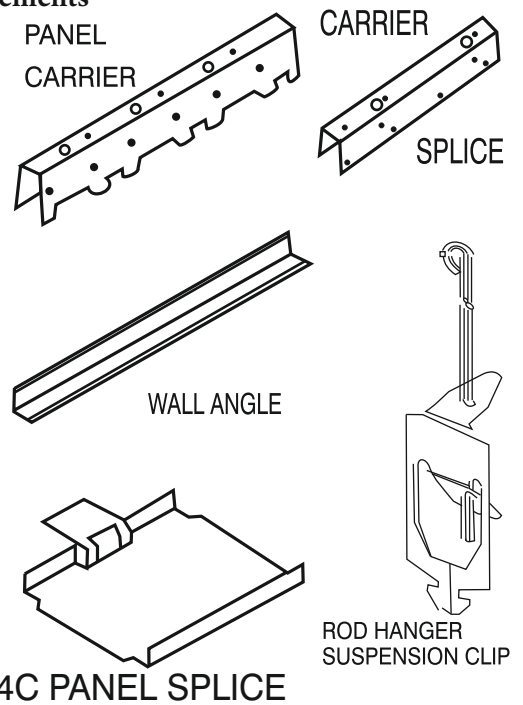

Metal used for construction of both panels and grid:

Aluminium Alloy AA5050, AA3105 or AA1050 is used to make the panels and carrier. Thickness is 0.5 mm for panels and 0.9/0.7 mm for carriers.

Panel are made of Galvanised steel with 120 gsm Zinc coating and 20 microns polyester paint coil coating sheets. Panels can be available in 60 microns polyester powder coating galvanised steel with 120 gsm Zinc coating or in aluminium alloy in different colours.

Finish of the panels: Panels are available in plain and perforation of 2.2mm, 2.5mm and 1.8mm

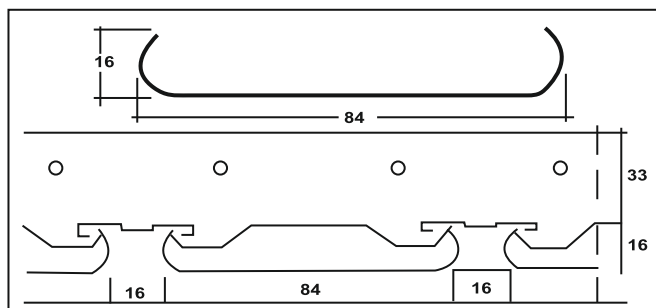

84 R Ceiling System

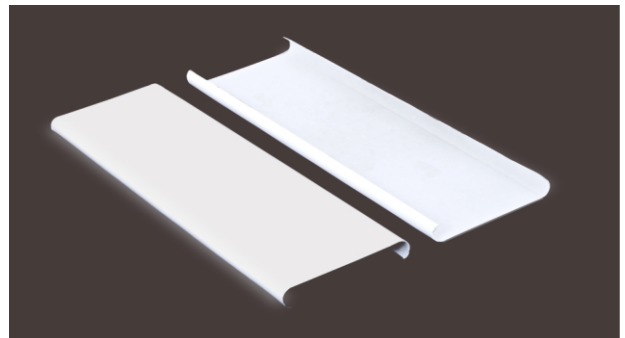

84 C/184 C LINEAR CEILING SYSTEM



Metafino 84 C /184 C ceiling system comprises of 84 /184 mm x 12.5 mm panels with 23.9 mm flange roll formed out of metal coils galvanized coil coated steel or aluminium alloy. Panels are fixed on to roll formed carriers 32 mm wide x 39 mm deep out of 0.9 mm Aluminium or 0.5 mm galvanized steel sheet with cutouts to hold the panels in module of 100 / 200 mm at maximum 1.5 m c/c without insulation and at maximum 1.2 m

c/c with insulation. Carriers are suspended from the roof or truss by 4 mm dia. galvanized steel wire rod hanger with special height adjustment suspension clip at max. 1.2 m c/c. Hangers are fixed to the roof by ceiling bracket. Panels are available in lengths up to maximum 5 m to suit site dimensions. Edge profiles or wall angles are 24 mm X 24 mm X 0.4 mm thick and match the colour of the panel.



Metal used for construction of both panels and carrier:

Aluminium Alloy AA5050, AA3105 or AA1050 is used to make the panels and carrier. Thickness is 0.5 mm for panels and 0.9/0.7 mm for carriers.

Panel are made of Galvanised steel with 120 gsm Zinc coating and 20 microns polyester paint coil coating sheets. Panels can be available in 60 microns polyester powder coating galvanized steel with 120 gsm Zinc coating or in aluminium alloy in different colours.

Finish of the panels: Panels are available in plain and perforation of 2.2mm, 2.5mm and 1.8mm

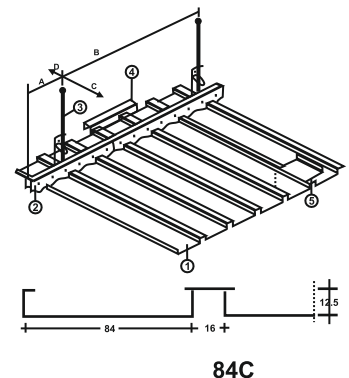
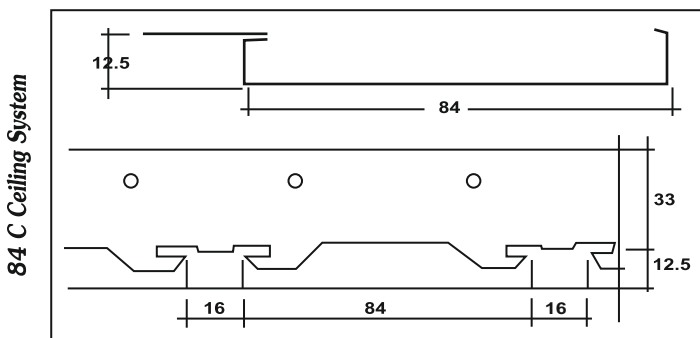

150 F LINEAR CEILING SYSTEMS

Metafino 150F ceiling system comprises of 150 mm X 17 mm. Panels are fixed on the roll formed out of metal coils galvanized coil coated steel or aluminium alloy. carriers 34.5 mm wide X 48 mm deep out of 0.9 mm Aluminium or 0.5mm galvanised steel with cutouts to hold the panels in module of 150 mm at maximum 1.5 m c/c without insulation and at maximum 1.2 m c/c with insulation. Carriers are suspended from the roof or truss by 4 mm dia galvanized steel wire rod hanger with special height adjustment suspension clip at max. 1.2 m c/c. Hangers are fixed to the roof by ceiling brackets. Panels are available in lengths up to maximum 5 m to suit site dimensions. Edge profiles or wall angles are 24 mm X 24 mm and match the colour



Aluminium - Alloy AA5050, AA3105 or AA1050 is used to make the panels and carriers. Thickness is 0.5 mm for panels and 0.9 mm for carriers.

Mild Steel - Galvanized with 120gsm Zinc coating,. Thickness is 0.5 mm for panels and 0.5 mm for carriers.

Finish of the panels: Panels are available in plain and perforation of 2.2mm, 2.5mm and 1.8mm

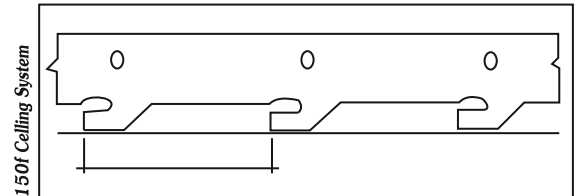
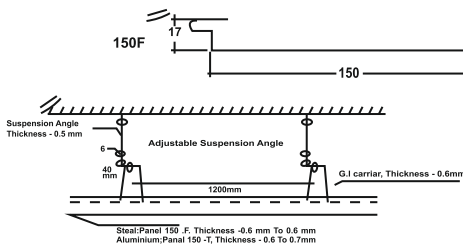

150 C LINEAR CEILING SYSTEMS

Metafino 150 C ceiling system comprises of 150 mm X 15 mm. Panels are made of roll formed metal galvanized coil coated steel or aluminium alloy 3105 coils with thickness 0.5mm or 0.7 mm. Aluminium Panels shall be powder coated with 60 microns polyester paint coating on front side or 20 microns front side and 8 microns backside for pre-coated G.I coils.

Panels are fixed on to roll formed carriers 30 mm wide X 40 mm deep out of 0.5 mm galvanized steel or 0.9 mm for aluminium sheet with cutouts / prongs to hold the panels in module of 150 mm at maximum 1.5 m c/c without insulation and at maximum 1.2 m c/c with insulation.

Carriers are suspended from the roof or truss by 4 mm dia. galvanized steel wire rod hanger with special height adjustment suspension clip at max. 1.2 m c/c. Hangers are fixed to the roof by 'J' hooks and nylon inserts. Panels are factory cut in lengths up to maximum 5 m to suit site dimensions or Architect Drawings.

G.I. Edge profiles or wall angles are 24 mm X 24 mm X 0.4 mm thick and match the colour of the panel.

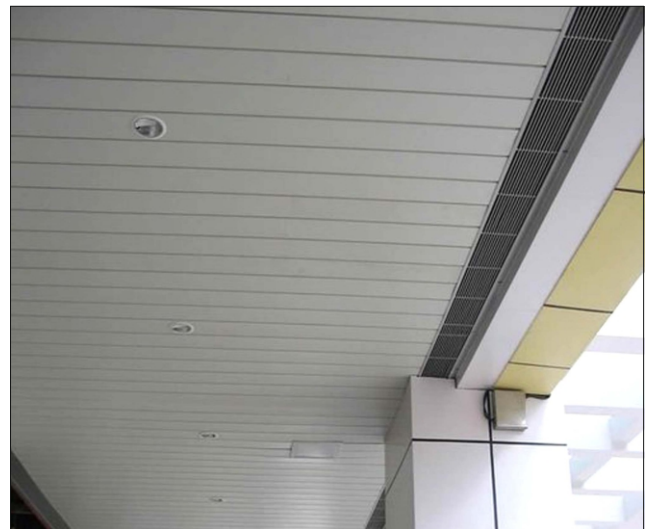

300 C LINEAR CEILING SYSTEMS



Metafino 300 C ceiling system comprises of 300mm wide x 30 mm. Panels are made of roll formed 0.5 / 0.7mm thick Aluminium sheet or 0.5 mm thick coil coated G.I sheets with bevel edge, panel length shall be up to 5 mtr. Panels shall be Pre-Coated 20 microns with polyester paint on the front side and 5-8 microns Primer coat on the back side. Powder coated Panels shall have 60 microns polyester paint on the front side only. Panel shall be clipped to Powder Coated G.I carrier of 41.5mm wide x 62mm deep x 0.5mm thick in standard length up to 5 mtr with cut outs to hold the panels in a module of 300mm closed at a distance 1.2 mtr. Panel carrier shall be suspended by means of G.I. suspension rod 4mm diameter and a Stainless steel suspension spring clip at a distance of 1.2 mtr c/c. G.I Edge profiles or wall angles are 24 mm X 24 mm X 0.35 mm thick shall be used on the walls with matching the

SUN LOUVER SYSTEM



Metafino Sun louver system is a highly functional, yet architecturally pleasing system that can add color and exciting design effects to a building façade. The system is available with panel set at the range of angles and a wide range of colors and size. Also, **Metafino** sun louver system provides for flexibility in design, easy maintenance and fast installation.

Metafino Aluminium Sun Louvres 84R system comprises of 84 mm wide and 16 mm deep roll formed out of aluminium coils. Panels are made of 0.5mm thick aluminium alloy. Carriers are made of 0.9mm thick aluminium alloy with cut-outs.

Metafino Sun louver system is a vertical wall sun shading system. The system use 84 R panels that snap into vertically mounted frames. The frames can be mounted on the exterior of a building over window openings, along balconies or over open area on a building elevation.

The vertical frames are offered in two different designs that hold the panels at different angles of 35 and 45 degrees. The ranges of angles provide air flow, sun shading, safety from rainfall and desired visibility.

BAFFLE CEILING SYSTEMS



We are manufacturing a quality range of Baffle Ceiling. Ideal for controlling sound reverberation from hard surfaces, these baffles are extremely useful in commercial and industrial areas. **Metafino** offers a variety of high performance acoustic hanging baffles in different sizes and shape. Baffle Ceiling is useful for many different types of area and application. Baffle Ceiling combine performance with high NRC Ratings and value for money to solve the most demanding of noise reduction problems. Baffles that mount up in the ceiling are one of the most effective methods to reduce reverberation and noise, because both sides of the baffle are exposed to the room. There are many types and coverings for indoor and outdoor applications. These Baffle ceilings are available in Galvanized Iron and Aluminum in a choice of different colors with 60 microns powder coating. All the sound baffles are fitted with hanging system used for vertical suspended or horizontal suspended from the ceiling. These baffles are light weight and do not add any extra load on ceiling.

Available Sizes: 25x50mm, 25x75mm, 25x100mm, 50x150mm, 50x200mm.

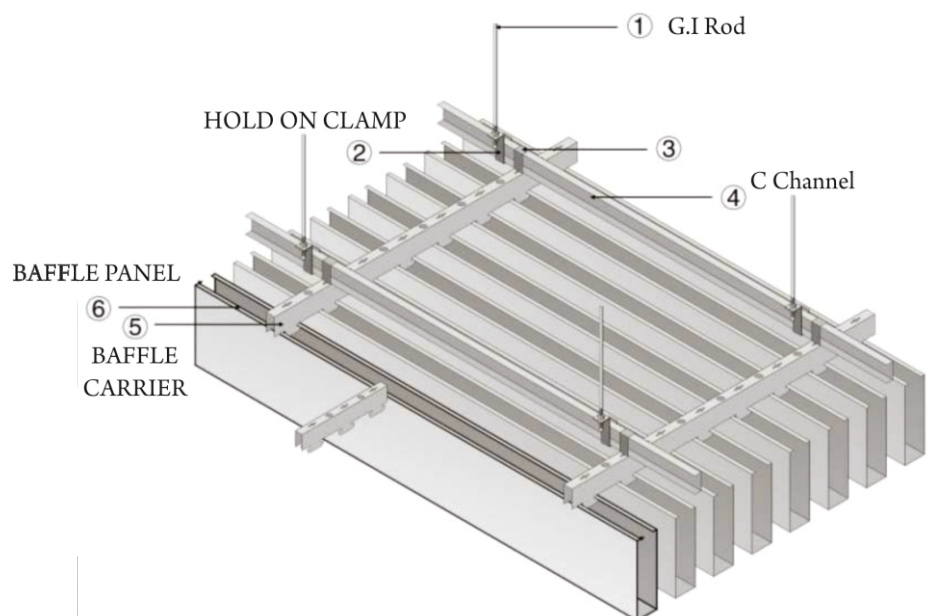
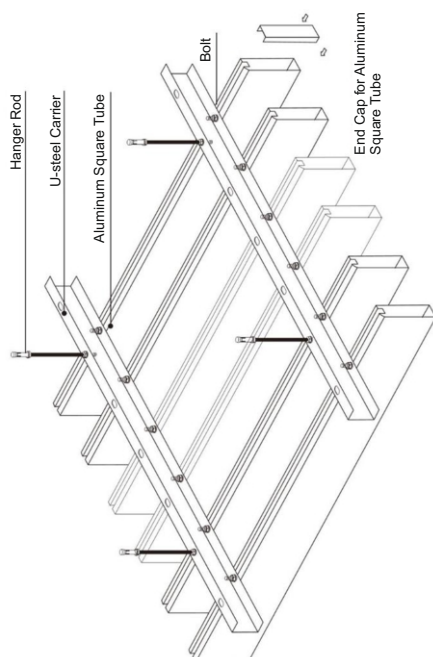



Hold on clamp C channel

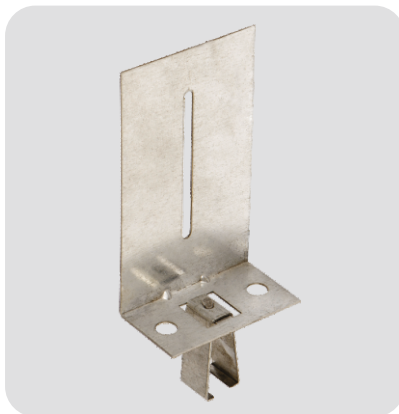

Hold on clamp Adjustable



Hold on clamp with Butterfly



Hold on clamp wall



Wall Panel Splice 150 F



84C Panel Splice

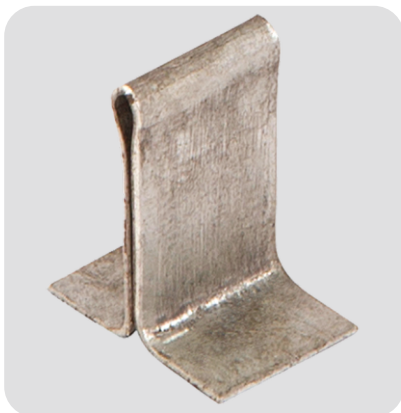

Pressure Clip



Suspension clip and Butterfly

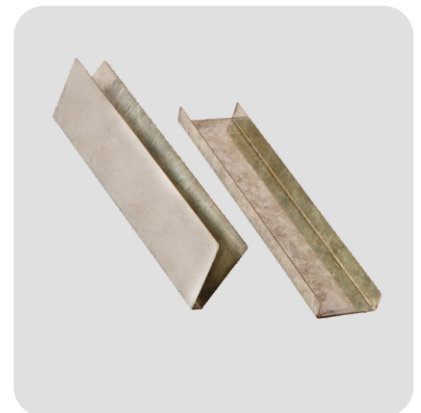

Jointer clip in Profile & C Channel



Hold on clamp



T Grid Clamp

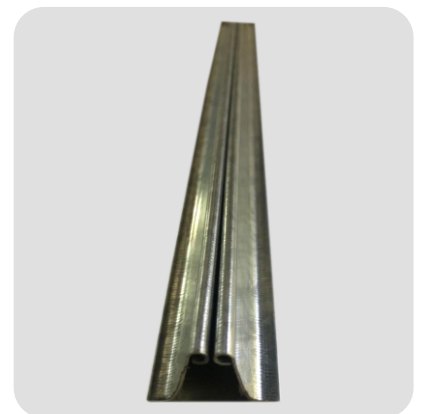

Clip in Profile

GYPSUM CEILING SECTION

CEILING SECTION

Technical Specification

| | |
|---------------|--|
| Basic Steel | Cold Rolled Steel |
| Galvanization | Hot Dip Galvanized (120 gsm) |
| Thickness | 0.40mm / 0.45mm / 0.50mm |
| Length | 3660 mm |
| Flange | Two equal flanges of 26 mm each and knurled web of 51.5 mm |

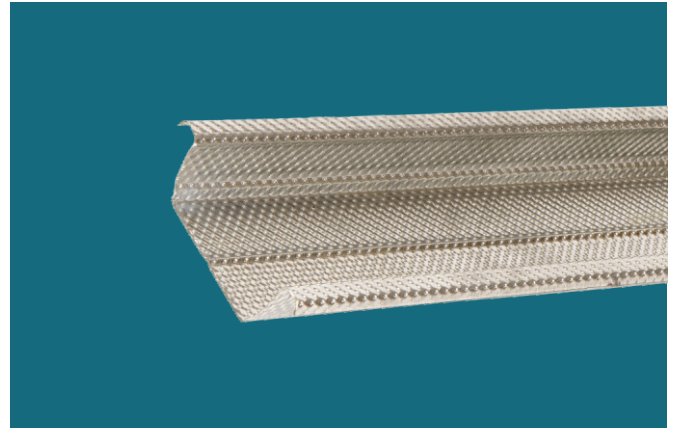

Application : It is a main supporting member which is suspended from the soffit with raw plug, soffit cleat and MS Flat from the soffit with rawl plug, soffit cleat and MS Flat at 1220 mm c/c in one row in 1220 apart.

INTERMEDIATE CHANNEL

Technical Specification

| | |
|---------------|---------------------------------|
| Basic Steel | Cold Rolled Steel |
| Galvanization | Hot Dip Galvanized (120 gsm) |
| Thickness | 0.80 mm / 0.90 mm |
| Length | 3660 mm |
| Flange | Two equal flanges of 15 mm each |
| Web | 45 mm |

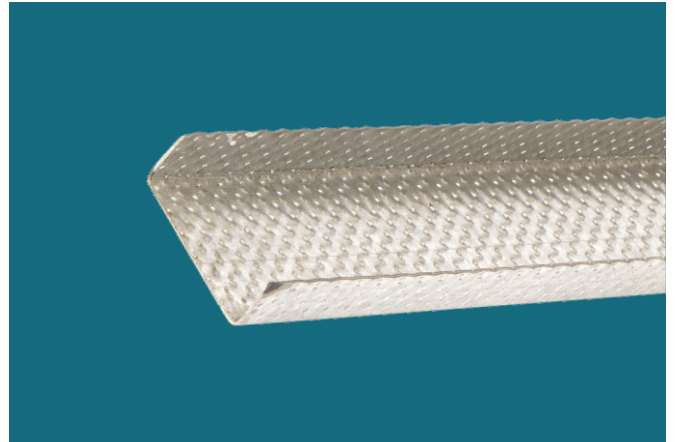

Application : Used on intermediate support to ceiling sections. it is used as a main supporting member at 1220mm c/c and is suspended from the soffit with the help of metal plugs and soffit cleat at 1220 mm apart.

PERIMETER CHANNEL

Technical Specification

| | |
|---------------|-------------------------------------|
| Basic Steel | Cold Rolled Steel |
| Galvanization | Hot Dip Galvanized (120 gsm) |
| Thickness | 0.40mm / 0.45mm / 0.50mm |
| Length | 3660 mm |
| Flange | Two equal flanges of 20mm & 30 each |
| Web | 26 mm |

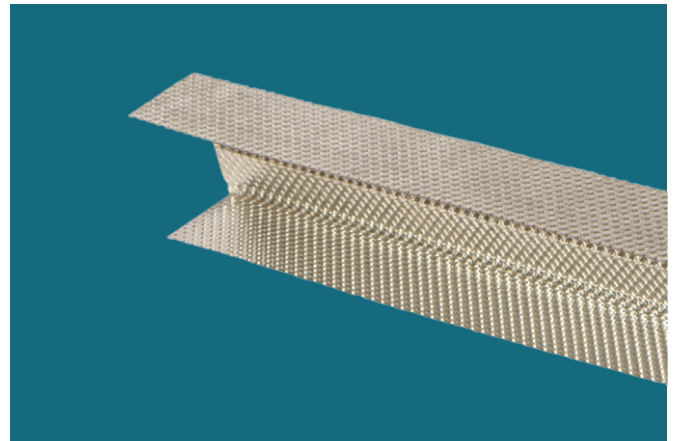

Application : It is used at the perimeter of the ceiling on to the wall/partition with the help of nylon sleeves and screw at 610 mm c/c.

GYPSUM CEILING SECTION

CEILING ANGLE

Technical Specification

| | |
|---------------|--|
| Basic Steel | Cold Rolled Steel |
| Galvanization | Hot Dip Galvanized (120 gsm) |
| Thickness | 0.40mm / 0.45mm / 0.50mm |
| Length | 3660 mm |
| Flange | Two flanges of 25mm x 25mm and 10mm x 25mm |

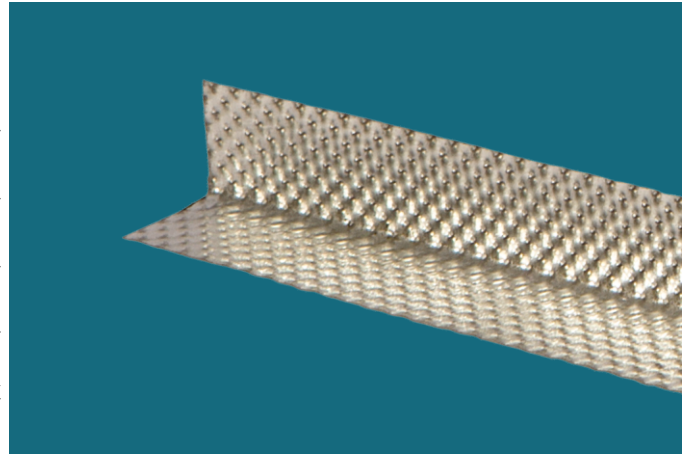

Application : It is used with gypsum board steel strapping in the coloum and beam encasement system at the flanges and for fixing the outer layer of a double layer partition at external angles

STUD SECTION

Technical Specification

| | |
|---------------|-------------------------------------|
| Basic Steel | Cold Rolled Steel |
| Galvanization | Hot Dip Galvanized (120 gsm) |
| Thickness | 0.50mm / 0.55mm |
| Length | 3660 mm |
| Flange | Two flanges of 36mm & other of 34mm |
| Web | 48mm, 73mm, 98mm |

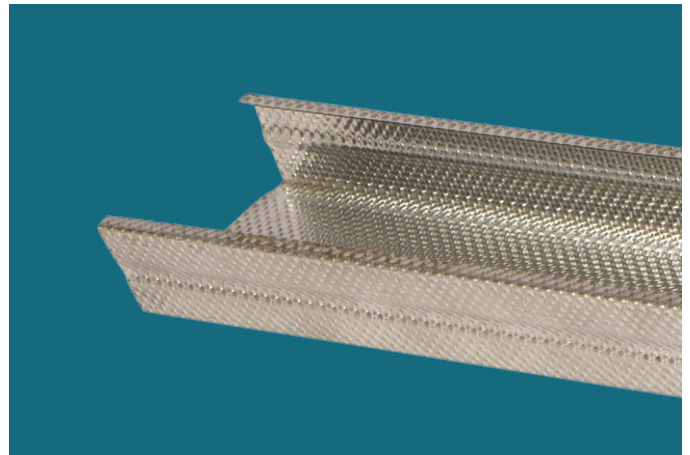

Application : It is used vertical member between the ceiling and the floor channels of metal framed partition system, it has knurling to increase strength.

FLOOR CHANNEL

Technical Specification

| | |
|---------------|-----------------------------------|
| Basic Steel | Cold Rolled Steel |
| Galvanization | Hot Dip Galvanized (120 gsm) |
| Thickness | 0.50mm / 0.55mm |
| Length | 3660 mm |
| Flange | Two equal flanges of 32 mm |
| Web | 50/75/100mm with a flange of 32mm |

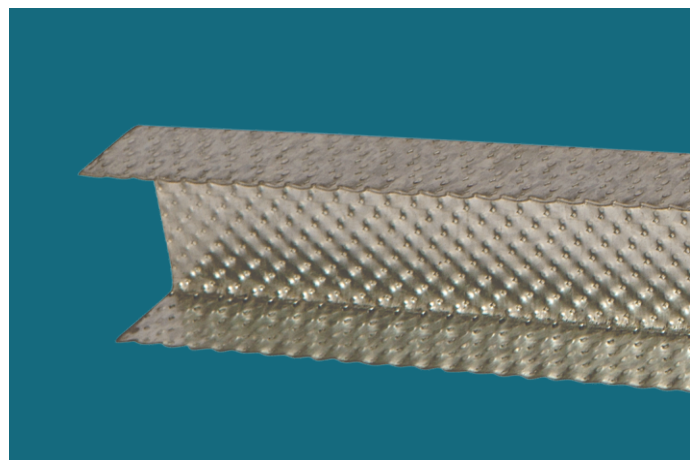

Application : It is used horizontal metal section at the ceiling and floor in metal framed partitions systems.

PARTIAL CHEMICAL COMPOSITION FOR ALUMINIUM ALLOY AS PER ASTM B209

| Element | Grade Symbol | 5050 Max. % | 1060 Max.% | 3105 Max.% |
|-----------|--------------|-------------|------------|------------|
| Manganese | Mn | 0.1000 | 0.0300 | 0.8000 |
| Silicon | Si | 0.4000 | 0.2500 | 0.6000 |
| Aluminum | Al | 98.8999 | 99.7999 | 99.4999 |
| Iron | Fe | 0.7000 | 0.3500 | 0.7000 |
| Chromium | Cr | 0.1000 | - | 0.2000 |
| Copper | Cu | 0.2000 | 0.0500 | 0.3000 |
| Magnesium | Mg | 1.8000 | 0.0300 | 0.8000 |
| Zinc | Zn | 0.2500 | 0.0500 | 0.4000 |
| Titanium | Ti | - | 0.0300 | 0.1000 |
| Vanadium | V | - | 0.0500 | - |

MACHANICAL PROPERTIES FOR ALLOY 5050

| TEMPER | TEMPERTENSILE STRENGTH (Mpa) | | | | ELONGATION % |
|--------|------------------------------|-----|-------|-----|-------------------|
| | ULTIMATE | | YIELD | | |
| | Min | Max | Min | Max | |
| H46 | 186 | 200 | 152 | 186 | min. 50 mm 6.3 |

SOME OF OUR PRESTIGIOUS CLIENTS



OUR PRODUCTS

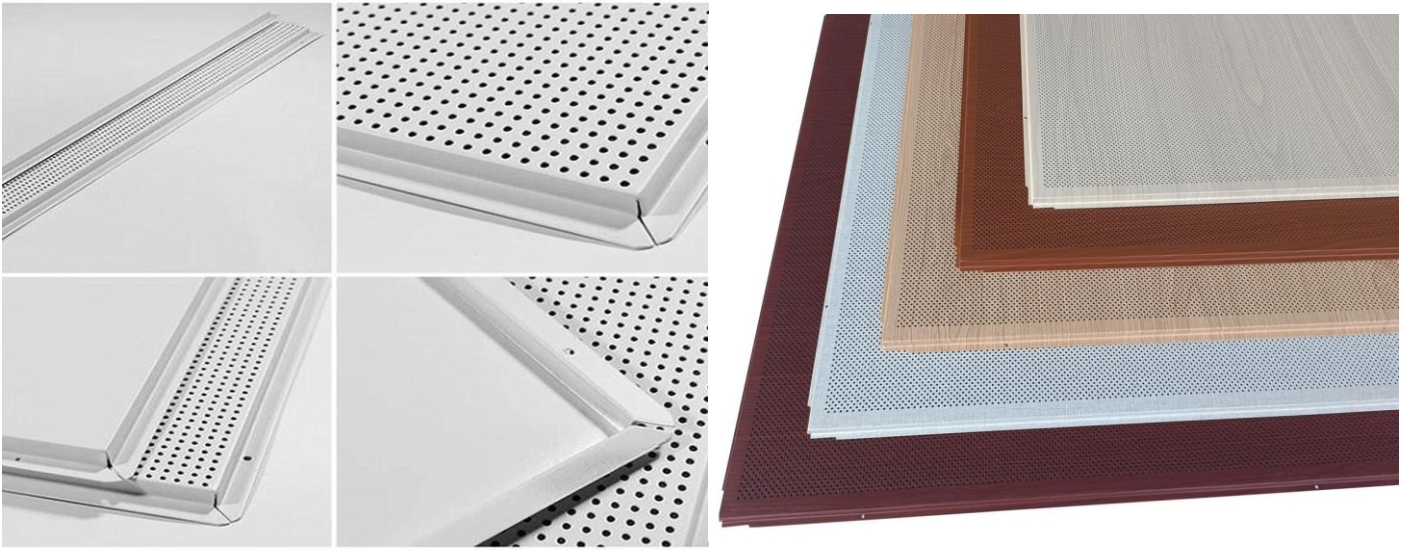

Stamp



PREKSHA INTERIORS PVT LTD

Office Address:

912-913, Aaron spectra, Behind the Rajpath club, Rajpath rangoli road, Bodakdev, Ahmedabad-380054

Contact us: +91 97277 10701

Factory Address:

Plot no-22&45, Akshar industrial park , opposite -Zudus cadila, At-chachrawadi Vasna, Sarkhej -Bavla road, Changodar, Ahmedabad

Contact us: +91 97279 82828

Showroom Address:

Shop no.3, GF, Panchvilla Tower, Opp.ladli party plot, buyangdev cross road to memnagar gam road , Memnagar, Ahmedabad -380051

Contact us: +91 97270 10701

www.prekshagroup.in | www.metafino.com